

MM FILTERS

Technical specifications

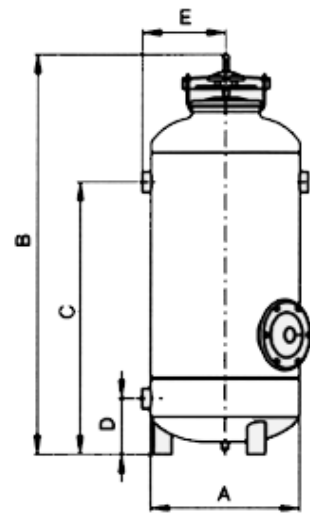

Drawing No. 1	16"	20"	24"
A	390	480	610
B	1185	1293	1287
C	876	880	880
D	185	180	180
E	219	266	331

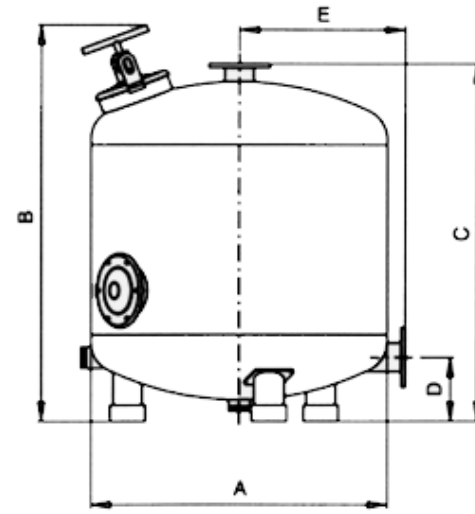

Drawing No. 2	30"	36"	42"	48"	60"
A	750	900	1050	1200	1500
B	1231	1219	1219	1186	1370
C	1100	1100	1100	1100	1265
D	196	196	340	365	400
E	430	505	585	660	814

Vessel name	16"	20"	24"	30"	36"	42"	48"	60"
Vessel diameter [mm]	400	500	600	750	900	1050	1200	1500
In/Out diameter	40mm; 1 1/2"	50mm; 2"	50mm; 2"	80mm; 3"	80mm; 3"	80mm; 3"	100mm; 4"	100mm; 4"
In/Out connection	Thread	Thread	Thread	Flange / Victaulic	Flange / Victaulic	Flange / Victaulic	Flange / Victaulic	Flange / Victaulic
Flow rate range [m ³ /h]	6-10	10-18	15 - 25	15 - 35	30-50	45-65	50-90	80-110
Bed depth [mm]	Basalt	100	100	100	100	100	100	100
	Quartz	400	400	400	400	400	270	300
Bed volume [liters]	65	100	140	220	318	320	452	707
Bed weight [kg]	20	150	180	280	400	360	560	1100
Weight w/o bed [kg]	55	75	95	155	200	245	285	400
Vessel volume [liters]	90	150	275	372	535	716	926	1465

Maximum working pressure	6.5 bar
Testing pressure	10 bar
Maximum temperature	60°C

Water treatment

12070 NW 40th Street Coral Springs, FL 33065
Ph. 954-857-1895 - www.advancees.com



Global provider of custom skid-mounted water purification equipment



FILTRATION SYSTEMS

Water treatment:

- Sand
- MM filters
- Activate carbon
- Green sand
- Iron removal

Versatile high-quality Media Filters solution for depth Filtration applications.

TECHNOLOGY AT WORK FOR YOU

Advanced Equipment and Services is a global provider of custom skid-mounted filtration systems that include many standard features which makes them suitable for the most demanding applications.

The steady growth and continuous success of the company is premised on innovative designs and quality without compromise. Our systems give you the reliability, durability, and performance you expect. We always incorporate the most advanced and reliable components to ensure you achieve the lowest operating cost during the whole system life.

OUR STANDARD MODEL SIZE RANGE

- 20 to 468 GPM

AA' - @9FGI'A98-5'

- Quartz
- Anthracite
- Green sand
- Carbon activated
- ####Lime
- ####Sand
- ####Gravel

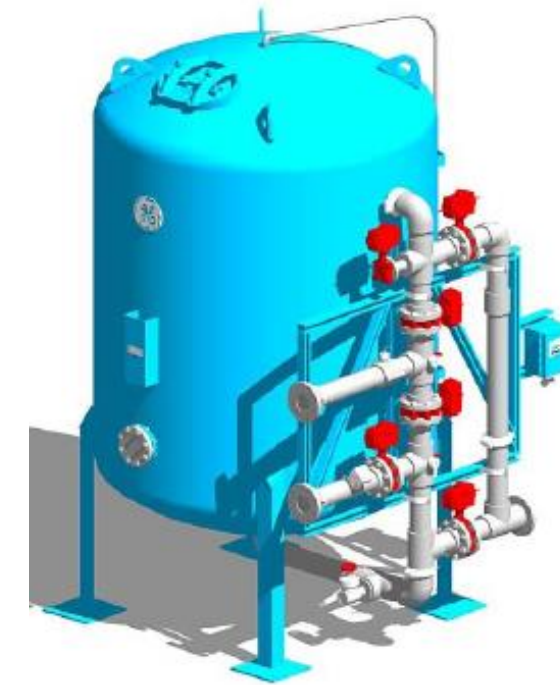

STANDARD BENEFITS:

- Complete filtration solutions; Custom designed, manual or Automatic backwash systems.
- Complete with manifolds, valves and controllers.
- Modularity and flexibility, Wide range of vessel types and sizes suitable for many filtration applications.
- High quality corrosion resistance vessels, Phosphate pre-treated, Polyester coated steel.
- High efficiency; advanced design for perfect water distribution during filtering and backwashing.
- All filters are rated to 10 bars.
- Various bed types, Sand, Gravel, Active carbon, Anthracite, Basalt, etc.
- Various connection types, meeting all international standards.
- Meets ISO 9001 standards

flexible solutions for

ADVANCED ANCILLIARY EQUIPMENT

We know that you are looking for a comprehensive solution where the filtration system is just one piece in the puzzle. For this reason, we offer a complete line of ancillary equipment such as:

- Feed pump skid controlled by RO PLC
- Chemical feed systems
- UV Sterilizers
- Ozone systems
- CIP - cleaning in place systems

TRAINING AND SERVICES

We provide a complete line of services that include but are not limited to commissioning, start-up support, operators training, troubleshooting training, modernization for old filtration systems, and retrofits to achieve optimum performance.



ADVANCED EQUIPMENT AND SERVICES PROVIDES THE BEST RETURNS YOUR INVESTMENT.

OPTIONAL FEATURES

Our standard units are designed with very robust components, but we understand that some customers have different needs for this reason.

We can offer the following optional components:

- Automatic self cleaning systems
- Semi-automatic cleaning systems
- Manual cleaning systems
- Data acquisition and logging systems
- Special instrumentation
- Screen filters
- Remonte monitoring

TYPICAL APPLICATIONS

- RO feed water pretreatment.
- Municipal
- Beverage and Bottling
- Hotels and Resorts
- Industrial
- Irrigation

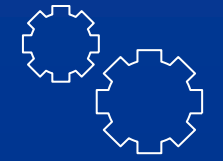

CUSTOM SOLUTIONS

If you do not find what you are looking, please feel free to send us the specification; we can build it with the reliability, durability, and performance you need. We provide comprehensive solutions to water problems.



WEB SOLUTIONS

Check us out at www.advancees.com for the latest updates regarding new developments in the water filtration world and other related and important information.



CONTACT US:

For easy and fast responses, please send your inquires to sales@advancees.com and shortly after one of our personnel will be in contact to discuss and answer your needs.

